

CONNECTOR

The heart of the lowering device is the patented spring assisted connector assembly. Each connector is comprised of a *socket half* and a *pin half*. After all the mechanical parts of the *Disconnect Unit* have aligned, the connector halves will engage to make electrical and signal contact. The socket half is secured to the fixed portion of the *Disconnect Unit* and the pin half is attached to the moveable portion. Spring assisted socket half maintains constant pressure on the pin half ensuring complete insulation of contacts.

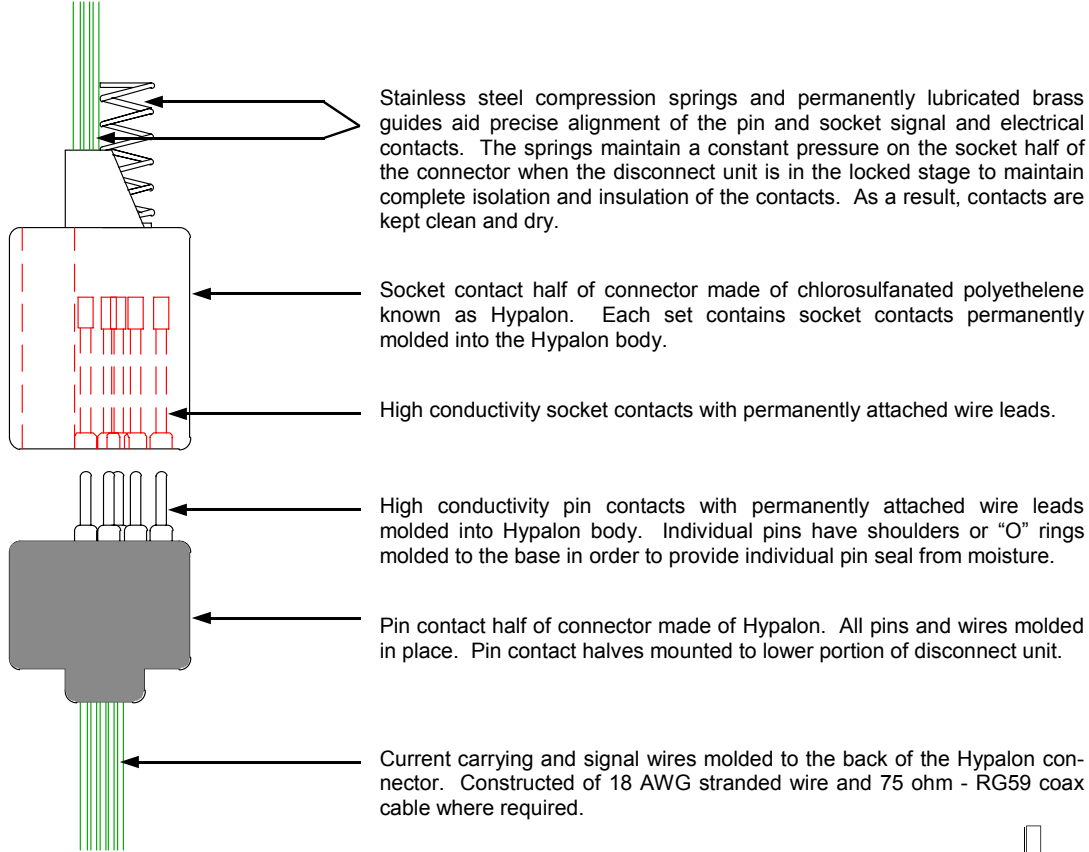

THE 5 OPERATING STAGES OF THE DISCONNECT UNIT

When lowering or raising an ITS device, there are 5 basic steps, or stages that the *Disconnect Unit* goes through.

The principal part responsible for moving the support arms through the 5 stages is the **TRACKING GUIDE**. This guide is a precision cast series of angular surfaces strategically located to push the support arms in the required direction toward the center "L" notch. The two "L" notches support the entire load of the camera and components when the support arms are in the **LOCKED** stage. The drawing at right shows the path the support arms take through the tracking guide. Each Symbol represents one of the 5 stages.

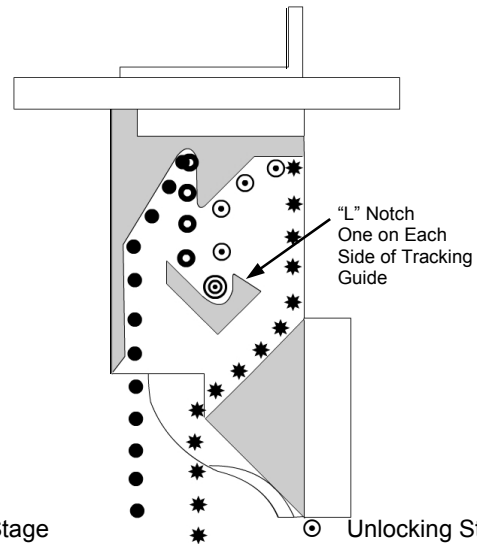

- Raising Stage
- Locking Stage
- ◎ Locked Stage
- * Lowering Stage
- ◎ Unlocking Stage

[MG]² INC. *The World Leader in Lowering Technology*

3301 Oak Hill Drive
Birmingham, AL 35216
USA

phone: (205) 823-6688
FAX: (205) 823-6615

E-mail: martin@mgsquared.com
Internet: www.LoweringSystemS.com

THE 5 OPERATING STAGES

1

The first and most important stage is **LOCKED**. Generally, all aspects of the operation of the *Disconnect Unit* will begin and end in the locked stage. In the locked position, the twin support arms hold all the weight of the surveillance camera. There is no tension on the operating cable, no locking of gears, and no pressure on braking devices to hold the camera secure in its operating position. The electrical and signal contacts are fully engaged and fully insulated and all camera functions are operational when the *Disconnect Unit* is **LOCKED**.

⊙ Locked Stage

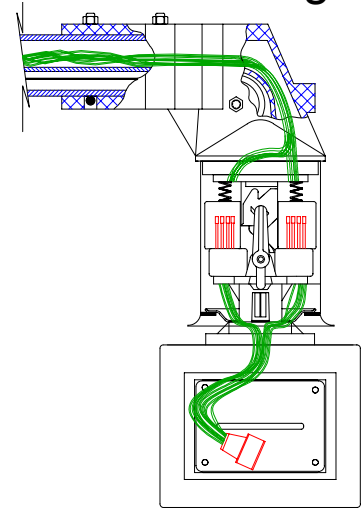

⊙ Unlocking Stage

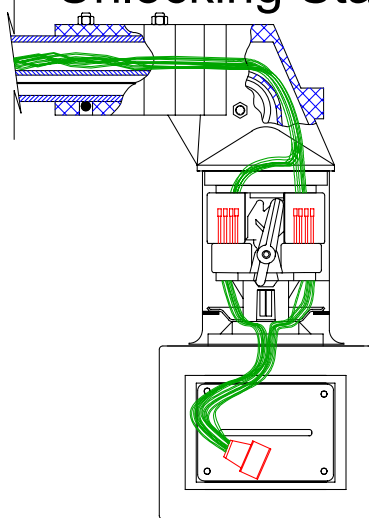

The second stage is **UNLOCKING**. Before lowering the camera, the *Disconnect Unit* must first be raised approximately $\frac{3}{4}$ inch. During the slight raising operation, the support arms will be pushed to one side by the tracking guide to clear the support notches. Springs inside the socket half of the connector compress as the *Disconnect Unit* is raised. Electrical and signal contacts are still engaged during this stage. Each *Disconnect Unit* has a built-in positive stop that, when reached, will alert the operator to begin lowering the camera. Every time the *Disconnect Unit* is raised from the "locked" position, the support arms will move and unlock the *Disconnect Unit*.

With the *Disconnect Unit* unlocked, **LOWERING** is the next stage. As the camera is lowered, the bottom portion of the *Disconnect Unit* begins to separate from the tracking guide and the top portion of the *Disconnect Unit*. Next, the electrical and signal connector disconnects followed by the coming apart of all stabilizing guides. All the weight of the camera and equipment now hangs from the control cable. There are no live electrical contacts to contend with as the camera is lowered to the desired height above the ground for maintenance. Cleaning and repair work can be accomplished at ground level.

★ Lowering Stage

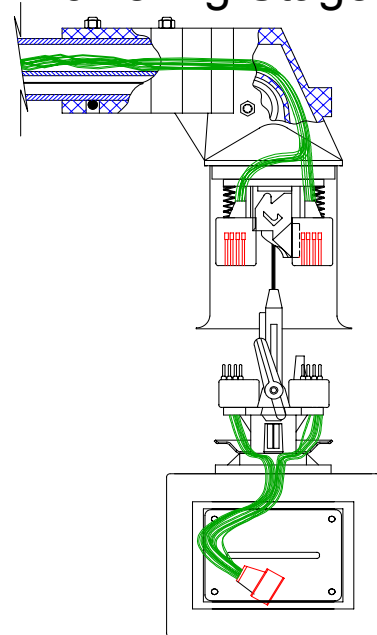

[MG]² INC. *The World Leader in Lowering Technology*

3301 Oak Hill Drive
Birmingham, AL 35216
USA

phone: (205) 823-6688
FAX: (205) 823-6615

E-mail: martin@mgsquared.com
Internet: www.LoweringSystemS.com

THE 5 OPERATING STAGES cont.

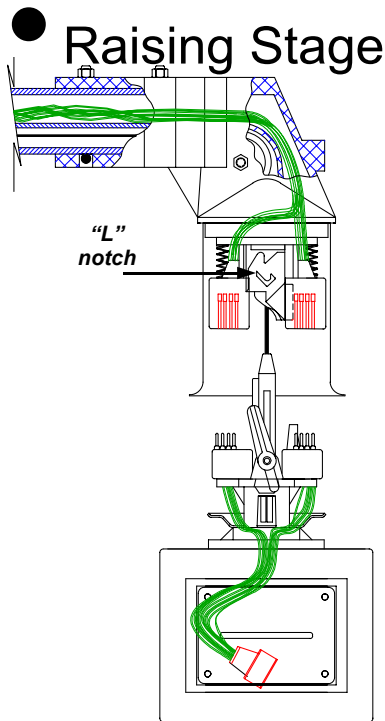

● Raising Stage

After maintenance to the camera, **RAISING** is the fourth of the operating stages. During this part, the camera and moveable portion of the *Disconnect Unit* are raised to the top. As the camera slowly approaches the upper portion of the *Disconnect Unit*, the control cable initially pre-positions the main guide post in the center hole of the tracking guide. With continued raising, the guide post centers itself in the tracking guide and rotates into its original orientation as the guide post's cast-in-place key follows the inclined helical surface of the tracking guide. Sustained raising of the camera will engage the next stabilizing key and guide slot of the *Disconnect Unit* as the support arms toggle through the tracking guide. Electrical and signal pins and sockets of the connector engage as the last step before the lower portion of the *Disconnect Unit* reaches the very top. Proceed to the final stage: **LOCKING**.

○ Locking Stage

The final phase of the 5 operating stages is **LOCKING**. During this stage, the camera must be lowered approximately $\frac{3}{4}$ inch so that the support arms of the lower portion of the *Disconnect Unit* move toward the center "L" notches of the tracking guide. Springs within the socket half of the connector that were compressed during the final part of the raising stage are now extending and exerting force on the pin half of the connector to assure complete isolation and insulation of the contacts. After the slight lowering operation, the dual support arms are secured in the "L" notches. The *Disconnect Unit* is now the **LOCKED** stage. The operating stages 1 through 5 may now be repeated over and over again with the camera returning to its original operating position each time. The operating stages of the *Disconnect Unit* always begin and end with the *Disconnect Unit* in the **LOCKED** position.

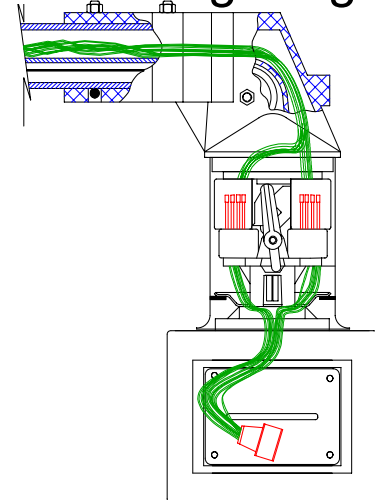

[MG]² INC. The World Leader in Lowering Technology

3301 Oak Hill Drive
Birmingham, AL 35216
USA

phone: (205) 823-6688
FAX: (205) 823-6615

E-mail: martin@mgsquared.com
Internet: www.LoweringSystemS.com

HOW IT WORKS

The **DISCONNECT UNIT** is responsible for the consistent realignment, locking and lowering of the mounted ITS device. Specially designed mechanical components assure precise alignment and positioning of the camera each time it is returned to its operating position after camera servicing. The patented spring assisted connector intrinsically handles all the multiple functions of the camera including power supply and video signal. Mechanical components, together with the connector, provide every **DISCONNECT UNIT** with the features required for operating surveillance cameras and other ITS devices.

DISCONNECT UNIT

Cross Section of Tracking Guide Showing Support Arms in Locked Position

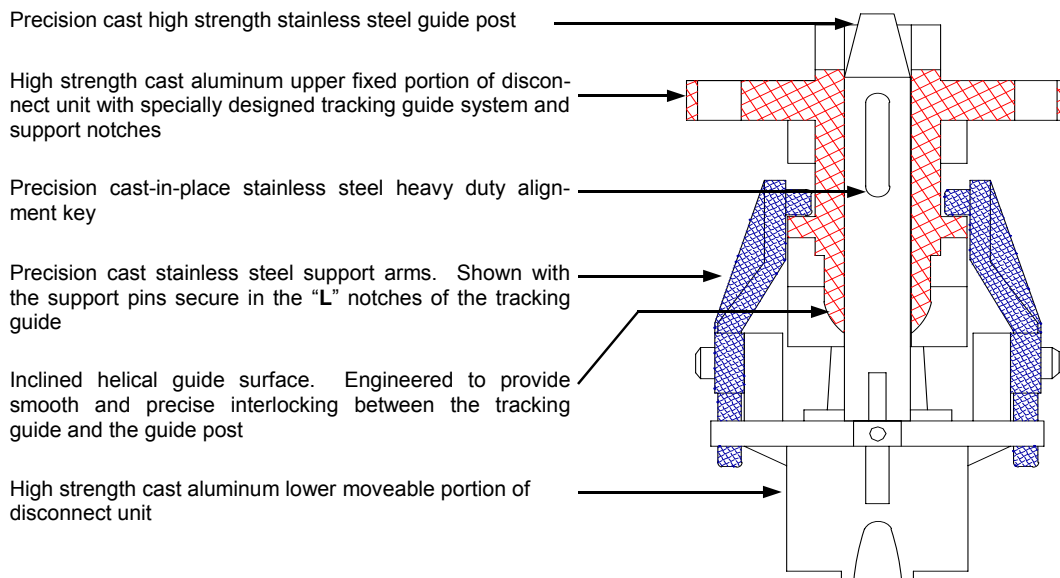

Pivoting Support Arms - Twin supports (highlighted in blue), precision cast in stainless steel, pivot as they move through a tracking guide to a locked position. Once locked, they assure a balanced load without relying on cable tension, motor gearing, or braking devices.

3-Way Stabilizing Guides - Prior to connector engagement, there are three stepped alignment and stabilizing guides integrated into the *Disconnect Unit*. **STEP 1:** A cast stainless steel guide post initially aligns the moveable portion with the upper fixed portion. With the aid of an inclined helical surface, the *Disconnect Unit* rotates into its preset position. **STEP 2:** A heavy duty key on the main guide post enters a stabilizing slot to stop rotation and align the support arms and connector. **STEP 3:** Offset at 180° to the main guide post key, a second key and slot engage to finalize alignment and stabilize the *Disconnect Unit* immediately before the pins and sockets of the connector engage.

[MG]² INC. *The World Leader in Lowering Technology*

3301 Oak Hill Drive
Birmingham, AL 35216
USA

phone: (205) 823-6688
FAX: (205) 823-6615

E-mail: martin@mgsquared.com
Internet: www.LoweringSystemS.com

©1998, 2002, 2006 [MG]²/ITS Products